

# Dimensions and Technical Specifications

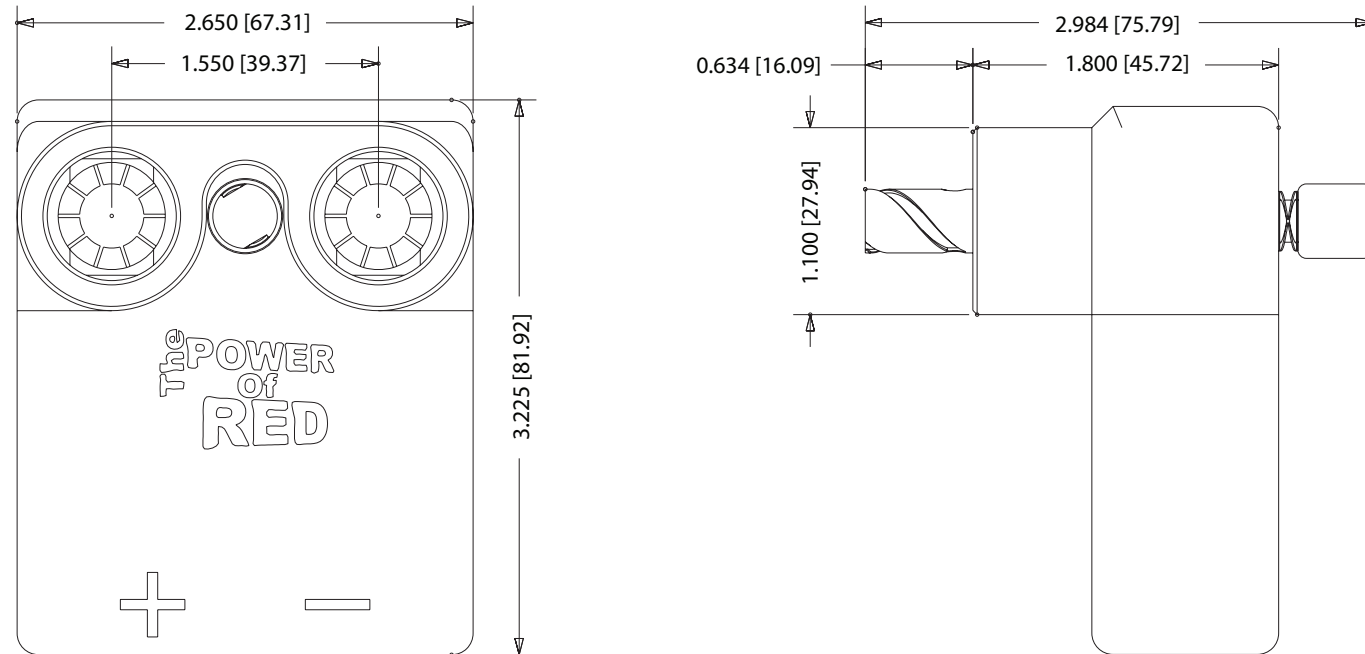

\* All dimensions are in inches [millimeters]

## Technical Specifications:

Input Voltage Range	9 - 36 VDC
Power Consumption (engaged)	72 mA
Power Consumption (disengaged)	0 mA
Maximum Current	650 A 1000 cycles
Continuous Current	200 A
Status Indicator LED	LED On/Off Indicator
Protection Class	DC Plug - IP28C Enclosure - IP68C
Air Gap-leakage Path	0.55" (14 mm)
Operating Temperature	-25° to 60°C (-32° to 140°F)
Storage Temperature	-40° to 85°C (-40° to 185°F)
Overvoltage Maximum	60 V
Weight (8 ft. cable)	7.5 lbs. (3.4 kg)
Warranty	2 years (3 years optional)

## TI2006-308 Universal Rescue Hoist Control Cable

The **TI2006-308 Universal Rescue Hoist Control Cable** uses state-of-the-art technology to operate helicopter rescue hoists (42305-1, 42305R1, 42305-3, 42305-5) outside of the aircraft. Repairs and testing can now be done safely and efficiently using power from any Tesla™ Ground Power Unit. Constructed from a rugged combination of space-age composite materials and corrosion-resistant alloys along with hermetically sealed control electronics, the Universal Rescue Hoist Control Cable will withstand the harshest battlefield conditions and other extreme environments while providing reliable switching up to 3000 peak amps.

### Features:

- Compatible with all Tesla™ GPU's
- Rated to 3000 peak amps
- Clamped cable connection
- UV, fuel, fungus, and oil resistant
- Easy component replacement
- Manufactured in-house
- Exceeds MIL-STD-810F
- Tested to withstand 50 G of force



Power Anytime, Anywhere



Tesla™ Industries, Inc.  
www.teslainsd.com  
Email: tesla1@teslainsd.com  
**Headquarters:** (302) 324-8910  
109 Centerpoint Blvd. New Castle, DE 19720 USA  
**Western Regional Office:** (775) 622-8801  
9475 Double R Blvd. Suite 2, Reno, NV 89521 USA



The **POWER OF RED**™



## Features and Benefits

### State-of-the-Art Control

The Tesla™ Universal Rescue Hoist Control Cable is equipped with a high current switchable control. A hermetically sealed toggle switch, along with a protective switch guard, allows the safe transfer of up to 3000 peak amps – no more arcing or fusing. When active, a status LED illuminates to let the user know power is present (see Figure 1).

### Weatherproof Construction

Through a series of strategically placed seals and bushings, the Tesla™ Universal Rescue Hoist Control Cable is hermetically sealed to lock out rain, snow, sand or any other form of damaging debris.

### Internal Cable Connections

Unlike connectors with cables that are molded directly to the housing, easily crimpable bullets (shown in Figure 4) allow for direct termination inside of the connector. Additionally, compression grommets provide strain relief. This eliminates the possibility of dangerous shocks from exposed wiring due to cable stretching.

### Replaceable DC Connector Contacts

Manufactured from highly conductive alloys, the contacts, (shown in Figure 5) feature threads that are resistant to damage and ideal for superior torquing and surface contact. Once installed, the contacts are hermetically sealed within the connector, yet can be easily replaced “in-the-field” without discarding the entire connector.

### Insertion/Extraction Tool

The Tesla™ Universal Rescue Hoist Control DC Plug can be easily repaired by replacing the contacts using the Insertion/Extraction Tool pictured in Figure 6. The tool and replacement contacts can be ordered through Tesla™ Customer Service at 302-324-8910.



Figure 1: Power at the flip of a switch.



Figure 2: Attaches easily to DC input on helicopter rescue hoist.



Figure 3: Rescue hoist control attached to a Tesla GPU.

## Components - Exploded View

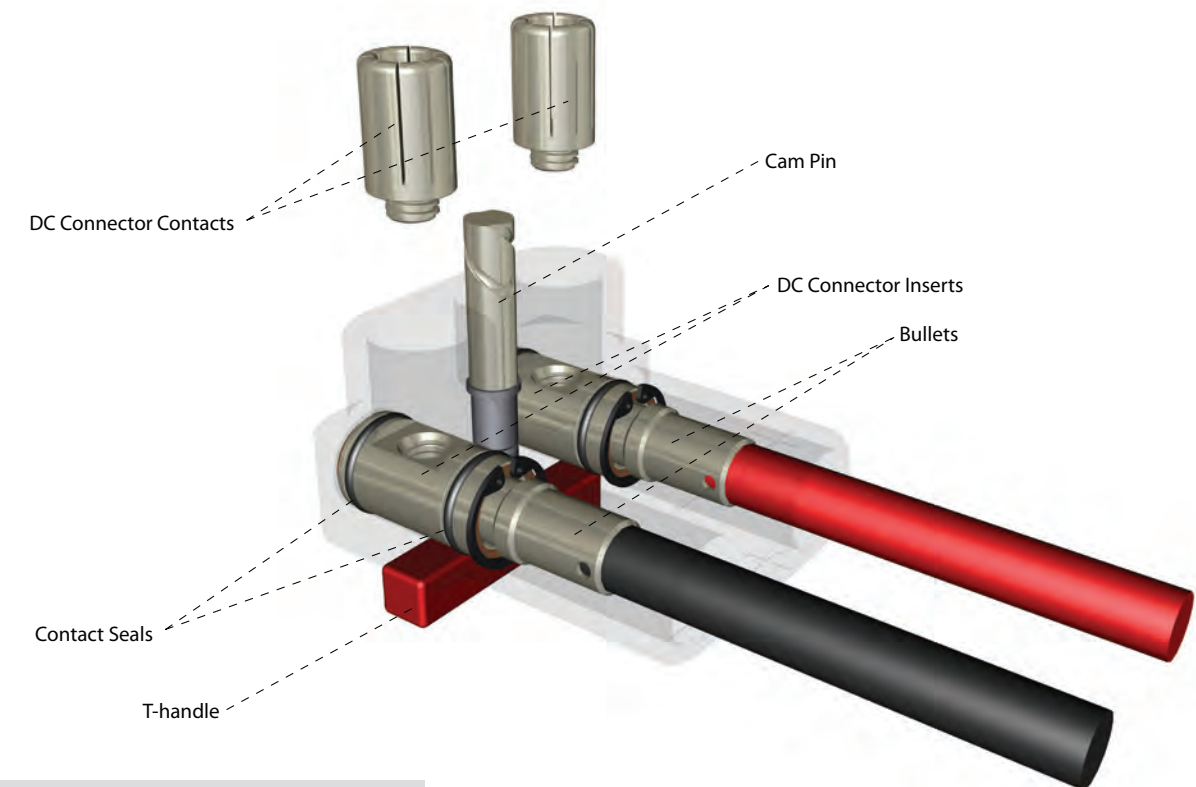

Figure 4: Cable Crimp Bullets: TI2005-199



Figure 5: DC Plug Replacement Contacts: TI2005-490



Figure 6: Insertion/Extraction Tool: TI2005-488



Figure 7: The TI2006-308 DC Universal Hoist Control Cable is designed to withstand daily military testing.