



*Power Anytime, Anywhere*

# Tesla™ TI2000-054 Transformer

## User Manual



*Built Smart...Proven Tough*

**Tesla Industries, Inc.**  
109 Centerpoint Blvd.  
New Castle, DE 19720  
(302) 324-8910 Phone  
(302) 324-8912 Fax  
[www.teslaind.com](http://www.teslaind.com)

7-14-2010



**NOTE: All users must read this entire manual prior to operating the TI2000-054 Transformer.**

The TI2000-054 Step Down Transformer is a limited maintenance-free and sealed unit. No repairs are authorized. Warranty will be voided if unit is tampered with in any way, or if unauthorized repairs are made. For technical support please contact:

TESLA™ INDUSTRIES INCORPORATED  
109 CENTERPOINT BLVD.  
CENTERPOINT INDUSTRIAL PARK  
NEW CASTLE, DELAWARE 19720  
PHONE: (302) 324-8910  
FAX: (302) 324-8912  
WEBSITE: [www.teslaind.com](http://www.teslaind.com)  
EMAIL: [tesla1@teslaind.com](mailto:tesla1@teslaind.com)



**CAUTION**

**SHOCK HAZARD POTENTIAL**

Improper use or failure to follow instructions in this user manual can result in unit damage and/or injury or death by electrical shock.

Any attempts to open or examine the inside of the TI2000-054 Step Down Transformer via a tool or device (borescope, probe, etc.) can result in unit failure and/or injury by electrical shock.

Always protect the unit from short circuit.

No part of this manual may be reproduced or transmitted in any form or by any means, electronic or mechanical, including photocopying, recording, or any information storage and retrieval system, without prior written permission from Tesla Industries, Inc.

Copyright © 2010 by Tesla Industries, Incorporated. All rights reserved.



# Table of Contents

Section 1 – Product Overview	1
1.1 – Introduction	1
1.2 – Use of Words: Shall, Should, May	1
Section 2 – Safety Review	3
2.1 – Safety Notices	3
2.2 – Symbols	3
2.3 – Hazards	4
2.4 – Important Safety Precautions	4
2.5 – Extreme Environments	4
Section 3 – Unit Specifications	5
3.1 – General Specifications	5
3.2 – Physical Dimensions	6
3.3 – Airflow Ports	7
Section 4 – Features	9
4.1 – Features Overview	9
4.2 – 480 VAC Input	10
4.3 – 280 VAC Output	11
4.4 – Phase Indicator lights	12
4.5 – Fuses	13
4.6 – Transport Features	14-15
Section 5 – Pre-Operation	17
5.1 – Maintenance Checks	17
Section 6 – Operating Procedures	19
6.1 – General	19
6.2 – Operating Limits and Restrictions	19
6.3 – Connect to VAC Power	19
6.4 – Connect Ground Power Unit to Transformer	20
6.5 – Connect DC Cable to Ground Power Unit	20
6.6 – Connect DC Cable to Aircraft	21
Section 7 – Post-Operating Procedures	23
7.1 – General	23
Section 8 – Unit Care and Maintenance	25
8.1 – Unit Care	25
8.2 – Normal Functional Test Procedures	26-27
Section 9 – Frequently Asked Questions	29-30
Abbreviations and Definitions	31



# Section 1 – Product Overview

## 1.1 – Introduction

This manual contains the complete operating instructions and procedures for the TI2000-054 Transformer. The TI2000-054 Transformer is intended for converting 480 three phase VAC to 208 three phase VAC. This manual makes specific reference to the TI2000-054 Transformer being used as an accessory providing 208 three phase VAC to Tesla Industries Ground Power Units. The observance of procedures, limitations and performance criteria is essential to ensure peak operating efficiency and to maximize operational capabilities and life of the TI2000-054 Transformer.



Figure 1.1.1 – TI2000-054 Transformer

## 1.2 – Use of Words Shall, Should and May

Within this technical manual the word “**shall**” is used to indicate a mandatory requirement for proper operation and warranty purposes. The word “**should**” is used to indicate a non-mandatory but preferred method of accomplishment. The word “**may**” is used to indicate an acceptable method of accomplishment.





# Section 2 – Safety Review

## 2.1 - Safety Notices

Safety notices appear throughout this manual to alert the user to important information regarding proper installation, operation, maintenance and storage of the TI2000-054. These notices, as illustrated below, contain a key word that indicates the level of hazard and a triangular icon that indicates the specific type of hazard.

 <b>WARNING</b>	Indicates a condition, operating procedure or practice, which if not adhered to could result in serious injury or death.
--	--

 <b>CAUTION</b>	Indicates a condition or operating procedure, which if not strictly adhered to could result in damage or destruction of equipment.
--	--

 <b>DANGER</b>	Indicates a condition, operating procedure or practice, which if not adhered to could result in serious injury or death.
---	--

 <b>NOTE</b>	Indicates a condition, operating procedure or practice, which is essential to highlight.
--	--

## 2.2 - Symbols

The following symbols will appear within the warning triangles to alert the user to the specific type of danger or hazard.



General Warning

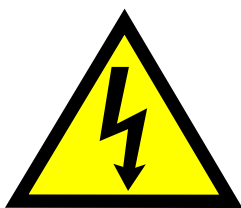

Electrical Hazard



Explosion Hazard



Fire Hazard



Battery Warning



Guard from Moisture

Figure 2.2.1 – Different types of hazard and caution symbols

## 2.3 – Hazards

**WARNING****SHOCK HAZARD POTENTIAL**

Severe injury or death from electrical shock will occur if either the user or the TI2000-054 is wet while operating the unit with the 480-208 VAC power source attached. Be sure to disconnect power from the source if the TI2000-054 has come into contact with water.

**WARNING****SHOCK HAZARD POTENTIAL**

Severe injury or death from electrical shock can occur when damp electrical plugs are connected to the TI2000-054. Make sure the electrical outlet is switched off before making any connections. Failure to use proper grounding can cause potential shock hazard!

## 2.4 – Important Safety Precautions

**WARNING****FIRE/EXPLOSION HAZARD POTENTIAL**

Severe injury or death from fire or explosion can occur if electrical sparks are produced near fuel vapors. To prevent this, make sure electrical outlets are switched to “OFF” position before connecting electrical plugs. For added safety, this unit shall not be operated during any aircraft fuel handling operation.

## 2.5 – Extreme Environments

**CAUTION****UNIT DAMAGE POTENTIAL**

The TI2000-054 is equipped with a charger temperature switch that automatically disables AC and charging functions when the internal temperature reaches above 150 °F (65 °C). This protects the unit from overheating and damage. If the unit shuts down, move the unit into a cooler climate such as shade or air conditioning when possible. Perform a full function test prior to use after the unit has been allowed to cool.

**NOTE: This Transformer is for Indoor use only.**

# Section 3 – Unit Specifications

## 3.1 – General Specifications

### Electrical

---

#### Input Power:

- 480 VAC / 18 Amps
- 3  $\emptyset$
- 50 / 60Hz
- 15 KVA
- 18 Amps
- Class 220°C
- 150°C Temperature Rise

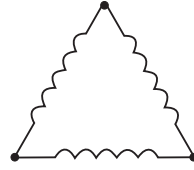

Delta

#### Output: Power

- 208 VAC
- 3  $\emptyset$
- 50 / 60Hz
- 15 KVA
- 42 Amps



Wye

#### Size:

- 22" long x 25" wide x 25" high  
558.80mm x 635mm x 635mm

#### Weight

- 195 lbs (88.45kg)

3.2 – Physical Dimensions

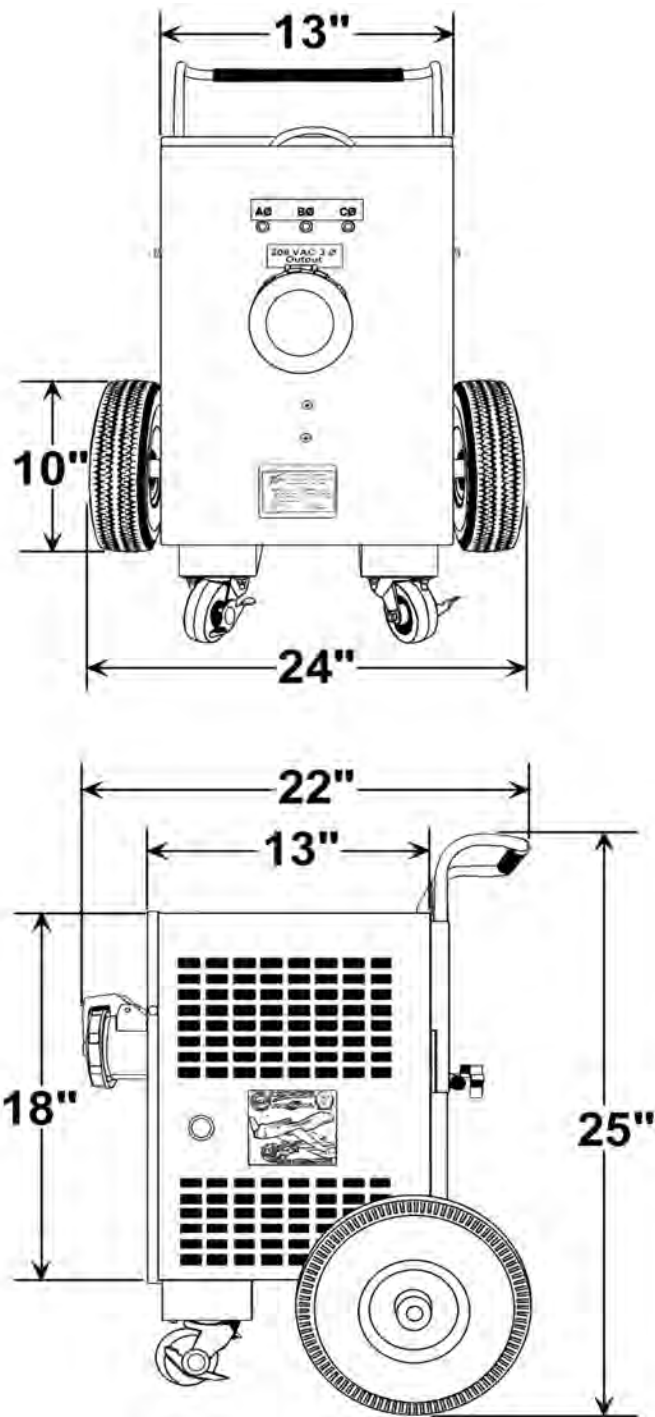

Figure 3.2.1 - TI2000-054 physical dimensions

### 3.3 – Airflow Ports



#### CAUTION

Damage may occur if the TI2000-054 Transformer's air intake or outlet ports are obstructed. Ensure that ports are clear at all times.

The TI2000-054 is intended for indoor use only. If outdoor use is necessary, contact Tesla for a sealed weather-proof cover. Make sure the airflow is not obstructed and air vents are clear. Do not allow foreign objects, blowing sand or dust to enter the air vents. Do not allow the unit to be exposed to precipitation or excessive moisture.

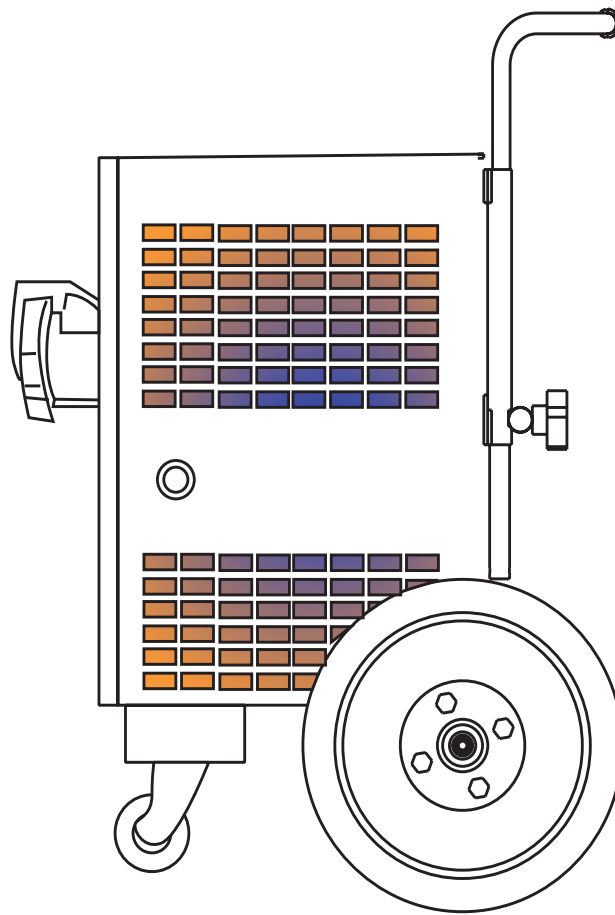

Figure 3.3.1 – Air intake and exhaust ports and internal air circulation



# Section 4 - Features

## 4.1 - Features Overview

The TI2000-054 is designed to convert 480 three phase VAC to 208 three phase VAC. The unit's exterior features an input receptacle, an output receptacle, phase indicator lights, and a telescopic handle and wheels for transport. The inside of the unit features replaceable fuses.

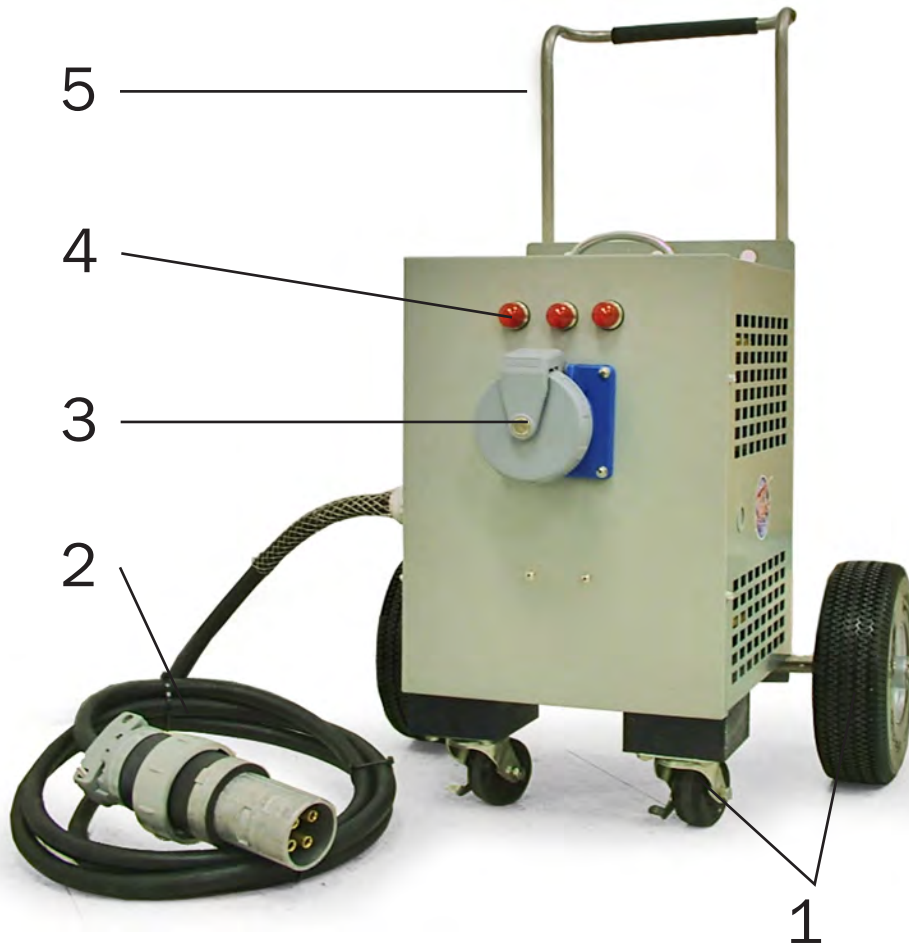

1. Locking Casters and Run-flat tires.
2. 480 Three Phase Input
3. 208 Three Phase Output
4. A, B and C Phase Indicator Lights
5. Telescopic Handle

### 4.2 – 480 VAC Input

The 480 Three Phase VAC input cable is twenty feet long with a plug.



Figure 4.2.1 480 VAC Input cable location



#### CAUTION

Unit may be damaged if incorrect AC power is applied. Check to make sure the unit is plugged into 480 phase VAC.



Figure 4.2.2 480 VAC cable plugged in.

### 4.3 – 280 VAC Output

The TI2000-054 has a 208 three phase VAC output located on the front of the unit. The output is a female receptacle and is used for plugging in the TI5400 GHMD male plug.



Figure 4.3.1 208 VAC Input cable location



Figure 4.3.2 208 VAC receptacle.



Figure 4.3.3 208 VAC cable plugged in.

### 4.4 – Phase Indicator Lights

The Phase indicator lights indicate that each phase is live. All three lights should activate when the unit is plugged into the AC power source. If all three lights do not activate then there is a problem with the AC power source. Disconnect the unit and troubleshoot the power source.



Figure 4.4.1 Phase Indicator Lights location



Figure 4.4.2 Indicator Lights OFF.

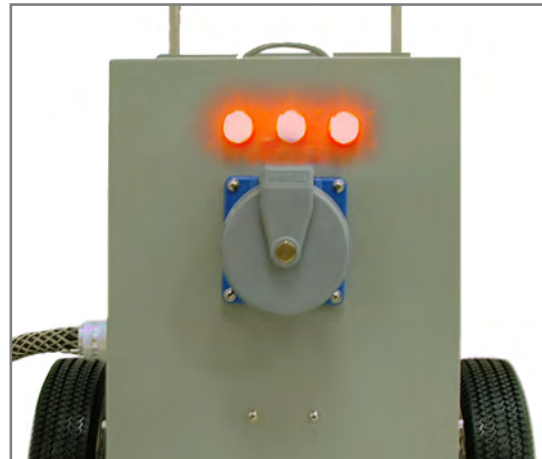

Figure 4.4.3 Indicators Lights ON.

## 4.5 – Fuses

To protect the unit from damage there are three fuses inside the unit. In order to replace the fuses the unit must be opened. The TI2000-054 has a three 30A 600V fuses located on the backside of the front panel. Check with multimeter to ensure the fuses are blown before replacing.



### CAUTION

Be sure unit is completely disconnected from power before opening unit.

**NOTE: This is the only repair authorized for the user. For all other repairs please contact Tesla's Customer Service Department at (302) 324-8910 with any questions or concerns.**

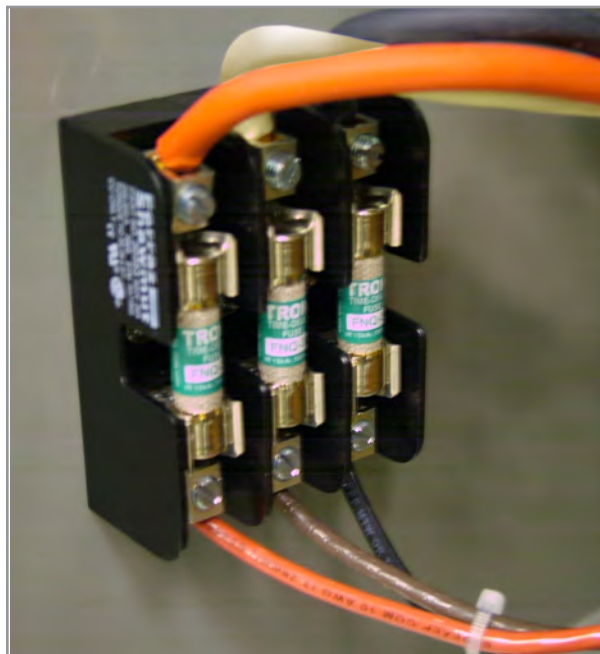

Figure 4.5.1 Replaceable Fuses

### 4.6 – Transporting Unit

The TI2000-054 has a telescopic handle that makes it easy to roll or push the unit. It is also equipped with four wheels.



Figure 4.6.1 Telescopic Handle and Wheel Locations

#### Lockable Casters and Run-flat Tires.

The Transformer is equipped with two ten inch run-flat tires and two lockable casters. The transformer can be maneuvered on all four or tilted with the handle onto the rear tires for transport.



Figure 4.6.2 Lockable Casters.



Figure 4.6.3 10 inch run-flat tires.

## Telescopic Handle.

The Transformer has a telescopic handle that makes rolling the unit easy.



1. Handle in down position.



2. Loosen knobs by turning counter clockwise.



3. Handle in up position.



4. Tighten knobs by turning counter clockwise.



# Section 5 - Pre-Operation

## 5.1 –Maintenance Check

Before operating the TI2000-054 check for any signs of damage or wear to the unit, tires, cables and plugs.

### Check Unit

Check the unit for dents, punctures, case distortion or mis-alignment, cracked or loose connectors. If no external damage is evident user may proceed. If damage is evident contact Tesla Industries.

### Check Tires

The TI2000-054 is equipped with solid Run-Flat tires. No air is required. However, if the tires are damaged they can be easily replaced.

### Check DC Power Cable And AC Power Cord For Damage

Crushed or torn cables will need to be replaced, before any operations can occur.

### Check DC Power Cable/Connections For Damage

Check connectors for cracks, cuts, distortions, excessive wear, broken/loose fasteners and cable attachment. Replace contacts or entire plug if necessary.



# Section 6 - Operating Procedures

## 6.1 – General

This section defines the operating procedures, which includes all steps necessary to ensure safe and efficient operation. Correct operation of the TI2000-054 includes both pre-use and operational checks of the unit. Knowledge of the operating limits, restrictions, performance, unit capabilities and functions is fundamental to correct and safe operation. The operator shall ensure compliance with the instructions in this manual that affect operational safety and the warranty of the unit.

## 6.2 – Operating Limits and Restrictions

The minimum, maximum and normal operating ranges result from careful engineering and evaluation of test data. These limitations must be adhered to during all phases of operation.

 <b>WARNING</b>	<b>FIRE/EXPLOSION HAZARD POTENTIAL</b>
--	--

Severe injury or death from fire or explosion can occur if electrical sparks are produced near fuel vapors. To prevent this, make sure electrical outlets are switched to “OFF” position before connecting electrical plugs. For added safety, this unit shall not be operated during any aircraft fuel handling operation.

## 6.3 – Connect to VAC Power

Plug the transformers VAC input plug into the appropriate 480 three phase VAC outlet. All three phase lights will come on. If all three lights do not activate then there is a problem with the AC power source. Disconnect the unit and troubleshoot the power source.

 <b>CAUTION</b>	Unit may be damaged if incorrect AC power is applied. The transformer must be plugged into a 480 three phase VAC power source.
--	--



Figure 6.3.1 Transformer connected to VAC Power

### 6.4 – Connect Ground Power Unit to Transformer

**NOTE:** Before plugging the unit into the Transformer switch the GPU's input power circuit breaker to the "OFF" position.

The T15400 400HZ GHMD can then be plugged into the transformer's output socket. Once the plug is securely in place, the input power circuit breaker can be switched to the "ON" position.

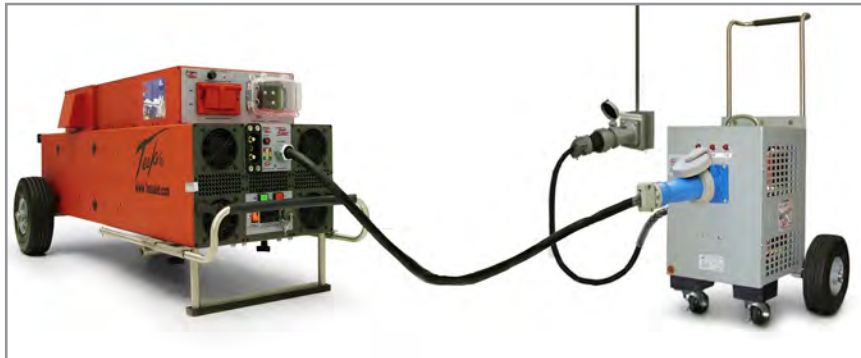

Figure 6.4.1 Transformer connected to GPU

### 6.5 – Connect DC Cable to Ground Power Unit

The chances of accidental arcing are low, but for added safety, press the DC Output "OFF" button. Ensure power cable connector is fully seated into the DC output receptacle.

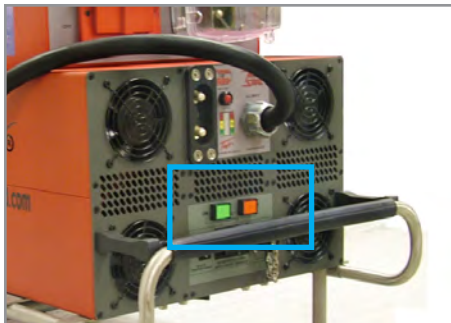

Figure 6.5.1 DC "ON/OFF" buttons location.

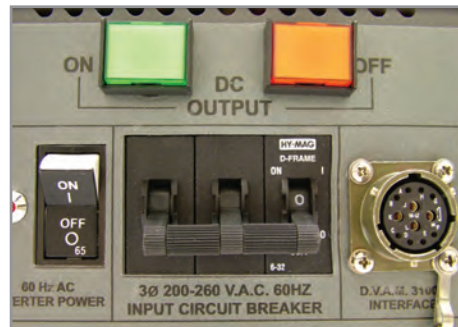

Figure 6.5.2 DC "ON/OFF" buttons.



Figure 6.5.3 DC cable plugged into GPU.

## 6.6 – Connect DC Cable to Aircraft

To prevent arcing while connecting DC power to the aircraft, press the DC output “OFF” button, then connect DC power to the vehicle. Ensure ground power cable connector is fully seated into aircraft receptacle. When you are ready to supply DC power, press the DC output “ON” button and it will illuminate. DC bus power should come on and the aircraft’s voltmeter should indicate 23.5 to 24 VDC (23 VDC minimum).

### Starting Aircraft Engine

Check power cable for security and correct installation prior to engine start. Follow ground power unit engine starting procedure as specified in aircraft operator’s manual.

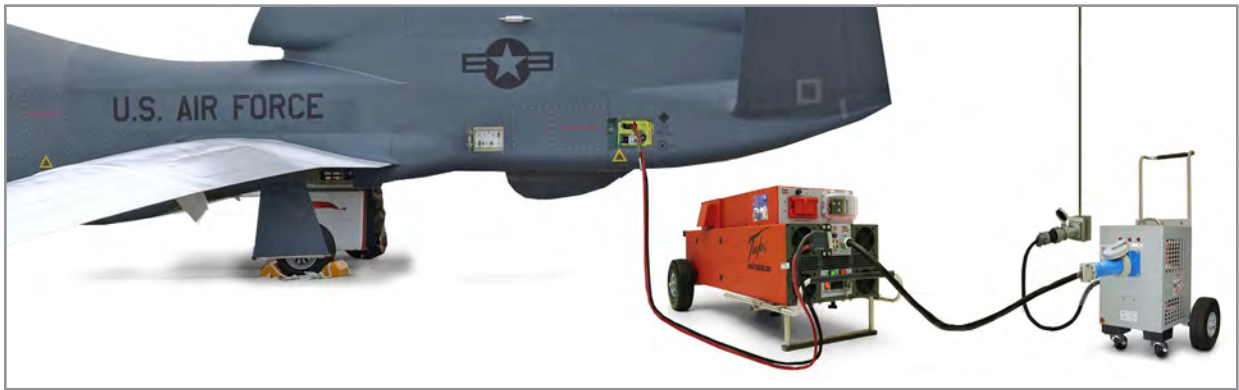

Figure 6.6.1 Connecting DC cable to aircraft and starting engine



# Section 7 - Post-Operating Procedures

## 7.1 - General

When not in use, the TI2000-054 Transformer should be covered and stored in a dry, temperature controlled area. Protect the unit from the elements and man-made hazards whenever possible. Make sure to keep the transformer's receptacle, plugs and air vents clear of debris. Disconnect unit and allow cooling time.





# Section 8 - Unit Care and Maintenance

## 8.1 - Unit care

### Avoid Prolonged Exposure to Extremely Damp Environments

Be sure to disconnect AC power from the AC source if the TI2000-054 has come into contact with water. If the fuse has tripped due to water seepage, allow the unit to dry out before attempting to replace. Cover the unit to prevent water seepage. If the unit is operated in extremely damp conditions, it should be stored in an environmentally controlled building when not in use. Wipe unit clean periodically with a soft cloth to remove dust, dirt, etc.

 <b>DANGER</b>	Severe injury or death from electrical shock will occur if either the user or the TI2000-054 is wet while operating the unit with an AC power source attached.
---	--



### Protect Cables from Damage

Do not cut, crush, or drag the input or output power cables when handling the TI2000-054. Always inspect cables prior to use. If no damage is evident, proceed to the next step. If damage is evident, contact Tesla™ Customer Service. Do not attempt to use any other type of power cables other than the Tesla™ cables included with the transformer.

 <b>CAUTION</b>	Damage may occur if an unapproved or modified AC line cable or input plug is attached to the GPU. Do not use any type of AC voltage converter.
--	--





## Check Unit Internal Resistance (Test for Shorts)

This section deals with “normal function” test procedures, and includes all steps necessary to ensure that the transformer is operating within specified parameters prior to use. A digital multimeter (an example is shown in Figure 8.2.1) capable of measuring DC and AC voltage and resistance will be required to perform some of the tests. These functional test procedures should become routine.



## Check Unit Approximately 120 VAC

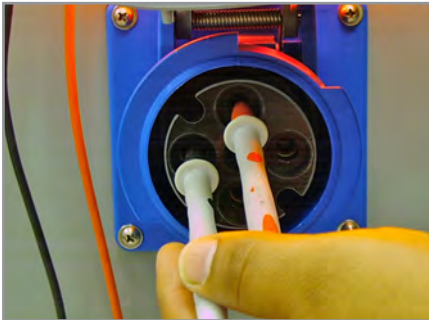

1. Place the negative probe on the receptacle's left ground insert and the positive probe on top side phase 1 insert.



2. Move the positive probe to the right side phase 2 positive insert.

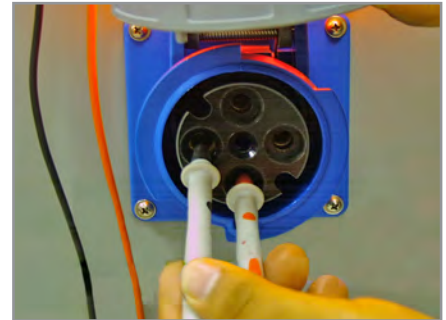

3. Move the positive probe to the lower phase 3 positive post.

## Check Unit Approximately 208 VAC



1. Move the negative probe to the upper phase 1 probe and the positive probe to right side phase 2 probe.

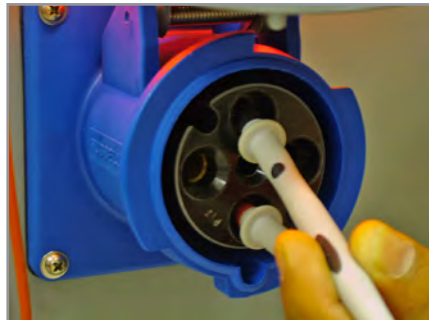

2. Move the positive probe to the lower phase 3 positive post.



3. Move the negative probe to the right side phase 2 probe and the positive probe to lower phase 3 probe.



# Section 9 – Frequently Asked Questions

## 1. Why should I buy a Tesla Turbo Start System?

Tesla Turbo Starts are multi-functional systems that are ideal for support of 24VDC vehicles and aircraft and their electronics/avionics on the bench. Tesla manufactures various systems, of different sizes and capacities, that are man-portable, maintenance free and provide pure, flat-line DC power in a completely safe package. Designed for Military applications, these systems are equally valuable in maintenance support at the main facility or in remote locations. They are easily transported and air-portable. They will also provide 28.5 VDC when the system is connected to the appropriate AC source.

## 2. How does a Turbo Start work?

The Turbo Start combines state of the art power conversion electronics with our proprietary “dry cell” batteries. The system’s electronics incorporate an intelligent charging system for the cells as well as an AC to DC converter. The cells are ideal for this application as they are non-spillable, absorbed electrolyte dry cells that are sealed, maintenance free and safe for air transport.

## 3. How are Turbo Starts used in Aviation Support?

There are many ways a Turbo Start will benefit your operation. By using it for pre-flight testing, you will avoid depleting the aircraft’s battery. You can start the aircraft’s engine with the Turbo Start as well. In the hangar, when connected to AC power, the Turbo Start will provide 28.5 VDC for avionics testing and will also recondition and recharge the aircraft’s battery. \*Another benefit is the ability to fly with the Turbo Start aboard your aircraft. You may take the Turbo Start anywhere you travel, ensuring that you will always have power.

## 4. How much power will my Turbo Start provide?

Depending on the system, the Turbo start will provide anywhere from 1500 to 3500 peak starting amps, 25 to 400 continuous amps DC and 23 to 96 hours of rechargeable power. See our website ([www.teslaind.com](http://www.teslaind.com)) to determine the proper Turbo Start for your needs.

## 5. Will a Tesla Turbo Start spool up a turbine engine?

Nothing will start a turbine engine faster or safer than the right Tesla Turbo Start. Not only will it eliminate hot starts, but it will extend the life of your starter, your engine and your battery while reducing maintenance. The Turbo Start senses the impedance from the starter/generator. It then provides the exact power required throughout the start-up curve.

## 6. How many engine starts will my Turbo Start provide until it is depleted?

The Turbo Start back-charges, almost instantly, once the vehicle / aircraft is started and the generator is on line. This “power flywheel” feature enables the Turbo Start to recharge itself right from the vehicle it started in less than 30 seconds. You can go down the line in your motor pool and start every 24V vehicle, without limit!

## 7. How do you prolong the life of the Turbo Start’s cells?

All you need to do is plug the unit in to the appropriate AC power outlet the system requires. AC power will recharge the system and keep the cells healthy. Users who regularly plug the system in can expect to get 5-7 years from their cells before they need to be replaced. Tesla cells do not have a memory like cell phone batteries. There is no need to fully discharge them. The recharging system will not overcharge the unit or produce excess heat.

## 8. Is it waterproof?

Water-resistant but not waterproof. Systems can be protected even greater with Tesla Rain covers. (see Rain covers page: 3-7)

## 9. Are Tesla GPUs used in shop maintenance and testing?

Tesla systems are gaining popularity throughout maintenance facilities, instructional facilities, laboratories, manufacturing plants, aircraft hangars and many other locations. The reason is due to the precise flat line DC power, the small, portable and quiet nature of our systems and the maintenance free aspect of our GPU's. We can custom tailor ground power systems to fit your individual requirements.

## 10. Can one person transport it?

Turbo Starts are designed to be handled by one person. The TI500 is our smallest GPU system to date and weighs 35 lbs. The TI1000 weighs 56 lbs and can be carried or wheeled on a dolly. Larger units have wheels incorporated directly on the system with an extendable handle.

## 11. Is the Turbo Start in the government purchasing system?

Yes. Tesla Industries is an approved vendor/supplier – our cage code is OVWE2. Most Tesla products are class IX, have a NSN (National Stock Number) designation and can be acquired through the DLA (Defense Logistics Agency).

## 12. How long does this unit stay charged?

Unit should never be allowed to discharge fully. In-field use, it receives a DC back charge directly from a running engine. When not in use, unit should be plugged into AC power (outlet) all the time. Tesla systems will retain 80% of their capacity after one year of storage.

## 13. How do I get my Turbo Start serviced?

Contact Tesla. We can be reached at 302-324-8910. Ask for customer service. You can also email us at [tesla1@teslaind.com](mailto:tesla1@teslaind.com). Once we receive the unit at our facility, we will examine it. Systems that are protected under warranty will be repaired at no charge. If the warranty has expired, you will receive a quote for necessary repairs prior to work being done. Our turnaround time is 48 hours once repairs are authorized.

## 14. Can I make my own repairs to unit?

During the warranty period, the unit can only be repaired by Tesla Industries for the warranty to remain in effect. Regardless, we strongly recommend allowing Tesla to repair any unit as we will analyze the complete system and re-calibrate it.

## 15. What type of maintenance does the Turbo Start require?

Although the systems are maintenance free, please keep units plugged in while not in use. This will greatly extend the life of the cells. Also, keep the vent areas clean and free of debris. Keep units in a well ventilated area while charging. Keep the unit in a protected environment when not in use (maintenance facility, shed).

## 16. What is included with my Turbo Start?

Aviation customers will receive an eight (8') foot DC cable with an aviation plug. Ground vehicle customers will receive a fifteen (15') foot DC cable with terminal ends. This cable requires a NATO plug, alligator clips or another connector prior to its use. Tesla can provide these connectors at an additional charge. Both customers receive an AC line cord for their home country and a full two year warranty. Axle extensions are included for wheeled single case units (TI2000 and TI3000).

## 17. Are there any HAZMAT issues or disposability problems?

There are none. Tesla will reclaim all battery cells for disposability purposes. Contact Tesla if you have questions.

# Abbreviations and Definitions

Abbreviations and definitions are used within text, headings and titles. Unless otherwise indicated, the following list of abbreviations and definitions are used in this manual:

## LIST OF ABBREVIATIONS AND SYMBOLS

Abbreviation	Definition
Amp	Ampere
AC	Alternating Current
C	Celsius
cont	Continuous
DC	Direct Current
F	Fahrenheit
Ft	Feet
FWD	Forward
GPU	Ground Power Unit
Hr	Hour
Hz	Hertz
Kg	Kilograms
KW	Kilowatts
°	Degree
LED	Light Emitting Diode
MAX	Maximum
MIN	Minimum
VAC	Volts, Alternating Current
VDC	Volts, Direct Current



# Repair Request Form

Please complete the information below to ensure prompt and accurate service. Include this form with the unit you are returning.  
Thank you.

Date of return: \_\_\_\_\_

Company name & \_\_\_\_\_  
\_\_\_\_\_  
\_\_\_\_\_

Billing address: \_\_\_\_\_  
\_\_\_\_\_  
\_\_\_\_\_

Contact person: \_\_\_\_\_

Phone #: \_\_\_\_\_ Fax #: \_\_\_\_\_

Purchase Order #: \_\_\_\_\_ EMail: \_\_\_\_\_

Model #: \_\_\_\_\_ Serial #: \_\_\_\_\_

Model #: \_\_\_\_\_ Serial #: \_\_\_\_\_

Shipping method to Tesla: \_\_\_\_\_

Description of shipping package: \_\_\_\_\_

Description of problem: \_\_\_\_\_

\_\_\_\_\_

\_\_\_\_\_

\_\_\_\_\_

**Return to Tesla™ Industries, Inc.**

109 Centerpoint Boulevard, New Castle, DE 19720 Attention: Repair Department