

# Dimensions and Technical Specifications

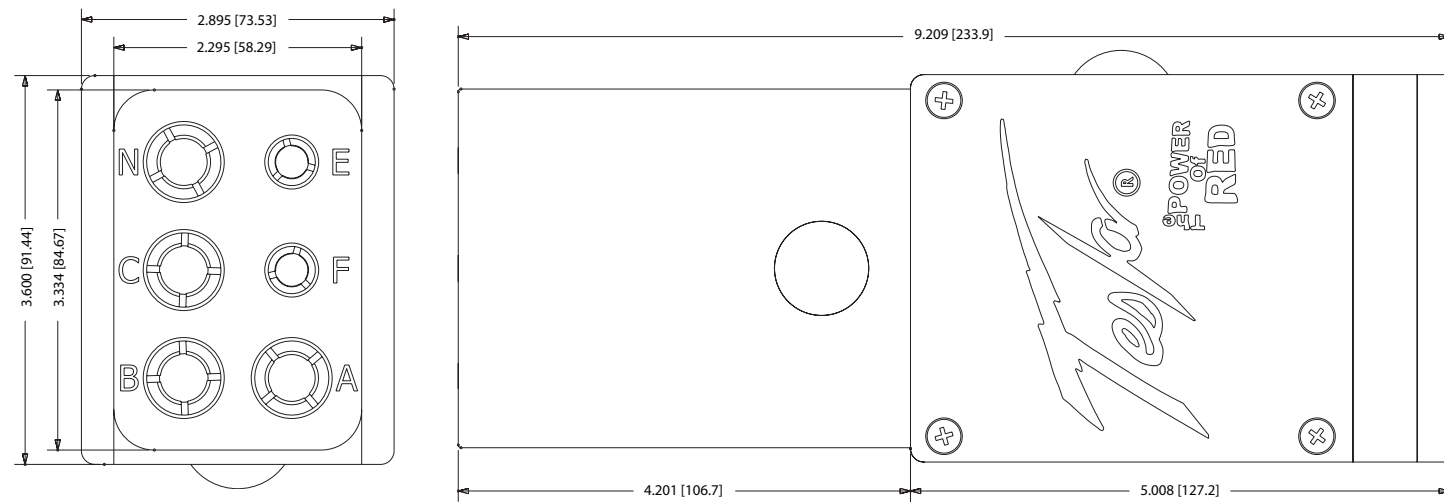

\* All dimensions are in inches [millimeters]

## Technical Specifications:

Number of Contacts	6
Cable Diameter Accepted	1.00" - 1.125" Multi-Conductor
Terminal Lugs	3/8 - 24 (power pins)
Peak Current	3000 A (power pins)
Storage Temperature	-65°C - 125°C (-85°F - 257°F)
Operating Temperature	-40°C - 110°C (-40°F - 230°F)
Air Gap-leakage Path	0.630" (16 mm)
Protection Class	IP28C (tested to 20 m)
Rated Current	1500 A
Rated Voltage	100 - 264 VDC
Dielectric Strength	> 6000 VDC for 1 min. across contacts
Insulation Resistance	4 GΩ w/1 kV across contacts
Contact Resistance	< 60 μΩ @ 25°C
Shock	50 G
Vibration	MIL-STD-810F
Engagement Torque	25 lbs (11.33 kg)
Weight	4.5 lbs ( 2.04 kg)
Warranty	2 years (3 years optional)

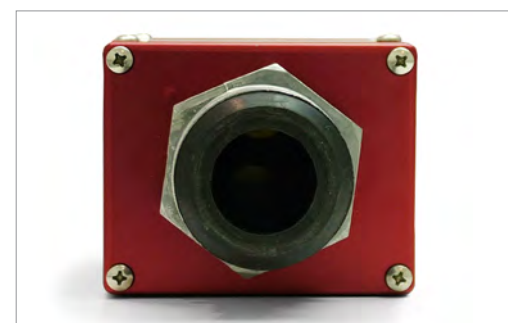

## TI2005-400 Cobra 400 Hz Aviation Plug



Power Anytime, Anywhere

The Tesla™ Cobra 400 Hz Aviation Plug is constructed from a rugged combination of space-age composite materials and corrosion-resistant alloys. The result is a waterproof 400 Hz aviation plug that will withstand battlefield conditions and other extreme environments. This virtually indestructible design, along with highly conductive contact materials and fast “in-the-field” component replacement make it the last 400 Hz aviation plug you will ever need.

### Features:

- Rated to 3000 peak amps
- Clamped cable connections
- UV, fuel, fungus, and oil resistant
- Easy component replacement
- Manufactured in-house
- Exceeds MIL-STD-810F
- Tested to withstand 50 G of force



### Contact:

Tesla™ Industries, Inc.  
www.teslaind.com  
Email: tesla1@teslaind.com  
**Headquarters:** (302) 324-8910  
109 Centerpoint Blvd. New Castle, DE 19720 USA  
**Western Regional Office:** (775) 622-8801  
9475 Double R Blvd. Suite 2, Reno, NV 89521 USA



## Features and Benefits

### Weatherproof Construction

Through a series of strategically placed seals and bushings, the Cobra 400 Hz Aviation Plug is hermetically sealed to lock out rain, snow, sand or any other form of damaging debris.

### Internal Cable Connections

Unlike connectors with cables molded directly into the housing, easily accessible lugs allow for direct termination inside of the plug. Additionally, compression grommets and bushings provide strain relief. This unique combination of protection eliminates dangerous shocks from exposed wiring due to cable stretching and splicing.

### Rugged, Durable, Reliable

Made from virtually indestructible composite materials, the plug housing won't crack, melt, blister, dry-rot or disintegrate. This, in conjunction with corrosion resistant conductors, insures that the Cobra 400 Hz Aviation Plug will still be in the field long after other plugs have failed.

### Replaceable Contacts

Manufactured from highly conductive alloys, the contacts are specially tapered and have memory to maximize contact surface area and to minimize deformity over time. Once installed, contacts are hermetically sealed within the plug.

### Insertion/Extraction Tool

The Cobra 400 Hz Aviation Plug can be easily repaired by replacing the contacts using the Insertion/Extraction Tool. The tool and replacement contacts can be ordered through Tesla™ Customer Service at 302-324-8910.



Replacement Contacts - A. Pos/Neg Contacts: TI2005-654  
B. 3 Slotted Connectors: TI2005-250



Cobra Aviation Insertion/Extraction Tool - TI2005-239

## Components - Exploded View

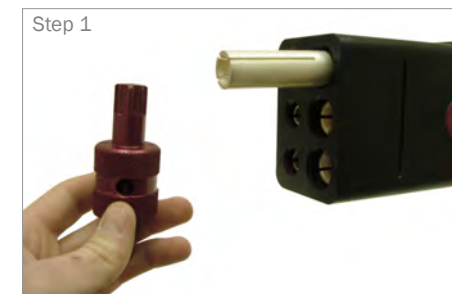
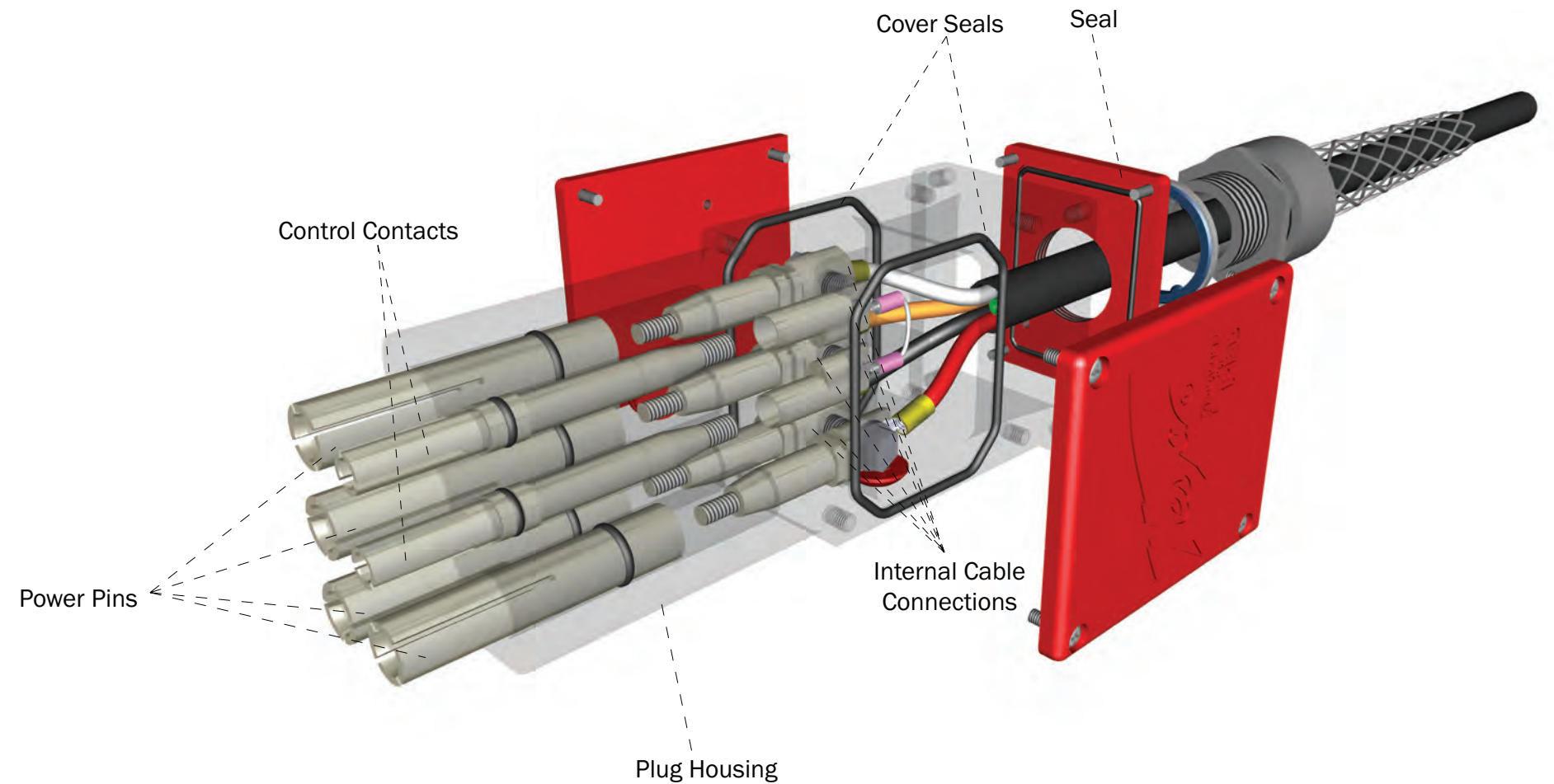

### Contact Replacement

**Step 1:** To remove the control pin, insert the smaller end of the tool and turn counterclockwise.

**Step 2:** To install a new pin, use the same tool and screw the contact in clockwise.

**Step 3:** To remove the power pins, insert the larger end of the tool and turn counterclockwise.

**Step 4:** To install a new pin, use the same tool and screw the new pin in clockwise.